

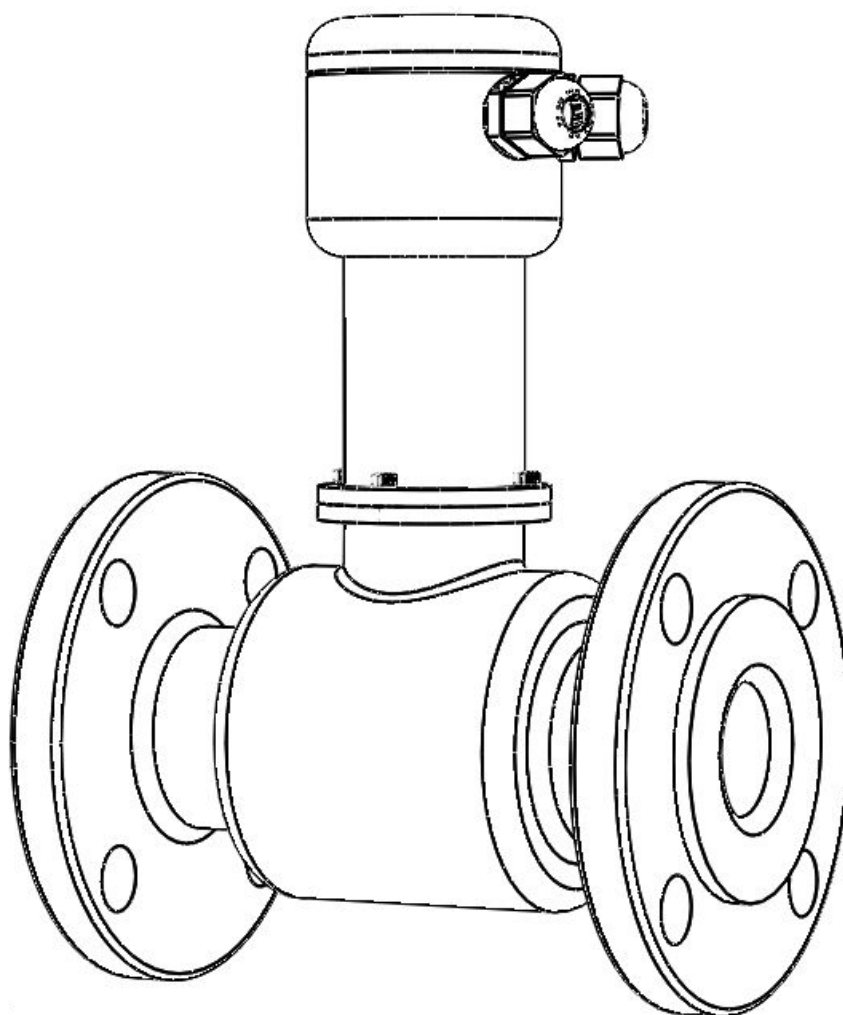

# USER MANUAL

## MAGNETIC - INDUCTIVE FLOWMETER

### MIE



Please read this manual before first use. The manufacturer reserves the right to make changes without prior notice.

## Notes

.....

.....

.....

.....

.....

.....

.....

.....

.....

.....

.....

.....

.....

.....

.....

# Contents

<b>Introduction</b> .....	4
<b>Technical conditions</b> .....	5
Measurement conditions .....	5
Sensor option .....	5
Main unit option .....	6
Connection and assembly .....	6
<b>Magnetic – induction sensors</b> .....	6
Tolerance of built-in lengths .....	7
Signal cable (connection between sensor and converter of the MIE-S) .....	7
Sensor location and its position in piping .....	8
Recommended positions for sensor installation .....	8
Recommendations for installation .....	9
Sensor grounding .....	9
Electrodes .....	10
<b>MIE commissioning</b> .....	10
Checking installation and connections .....	10
Service .....	10
Additional devices .....	10
Packing and transport .....	11
<b>Connection</b> .....	11
Sensor connection .....	11
Control unit communication connection .....	11
<b>MODBUS protocol</b> .....	12
MODBUS register .....	13
<b>Declaration of conformity</b> .....	14
<b>Specification</b> .....	15
<b>Adjustment protocol</b>	
<b>Warranty</b>	

## Introduction

**MIE** magnetic-inductive flowmeters (compact version: MIE-C, separated version: MIE-S) are precise measuring devices intended for the measurement of liquid flow of electrically conductive media. The meters may be used for measurements, registration, dosing, mixing, etc.

### Applications

- Water management, drinking and waste water measurement
- Chemical, textile, paper, mining industry
- Food industry
- Power engineering and heating plants
- Agriculture

### Main advantages

- Independent of power supply fluctuation and line voltage interference
- Independent of pressure, temperature and density, etc of the media
- No pressure losses
- No disturbances of measured liquid consistency

### Installation requirements

- Minimum liquid conductivity 5  $\mu\text{S} / \text{cm}$  (for demineralised water 20  $\mu\text{S} / \text{cm}$ )
- Fill the entire sensor profile
- Steady flow through the sensor (keeping the calming distances at the inlet and outlet)
- When selecting DN, it is necessary to consider the dependence of measurement accuracy on speed



### Principle of magnetic – induction sensor

The measurement is based on the principle of Faraday's law of electromagnetic induction. In compliance with this law, electric voltage is induced in an electrically conductive body, which moves across a magnetic field. The following equation is applied for voltage to be induced (generally):

$$\mathbf{U} = \mathbf{B} \times \mathbf{D} \times \mathbf{v} \quad \text{where:} \quad \begin{array}{ll} \mathbf{U} - \text{inductive voltage} & \mathbf{B} - \text{magnetic induction} \\ \mathbf{D} - \text{piping diameter} & \mathbf{v} - \text{flow speed vector} \end{array}$$

If magnetic induction  $\mathbf{B}$  and piping diameter  $\mathbf{D}$  are constant, then induction voltage is proportional to the mean

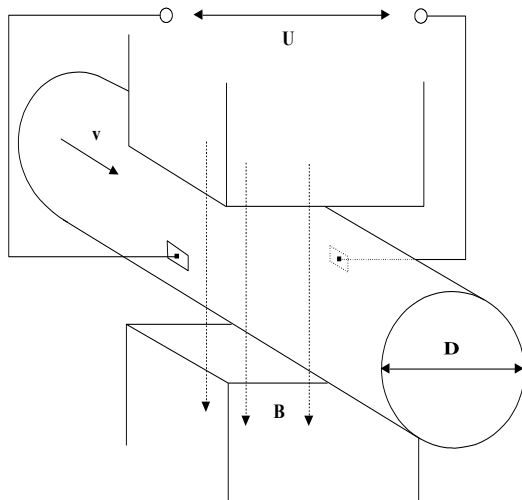

flow speed. Liquid is flowing via a flowmeter perpendicularly to the direction of the magnetic field. Electric voltage which is monitored by two electrodes placed perpendicularly to both magnetic field and flow is induced by a stream of liquid with minimum electrical conductivity. Excitation current with a rectangular waveform is generated in a converter and fed to sensor coil windings generating the flowmeter magnetic field. The forced-current system provides constant excitation under all conditions that can occur during the operation.

## Technical conditions

### Measurement conditions

*Measurement is independent up on:*

- Liquid temperature and pressure
- Liquid density and viscosity
- Solids contents
- Usual level of magnetic field interference

*For maintaining the MQI accuracy and reliability, it is necessary to meet the following conditions:*



- Electrical conductivity of medium  $\geq 5 \mu\text{S/cm}$ , for demineralized water  $\geq 20 \mu\text{S/cm}$
- Liquid velocity min. 0.3 m / sec, max. 12 m / sec.
- Steady flow section performance no DN change bevel pipe part(s) of maximum  $8^\circ$ .
- Steady flow section length 5 DN upstream / 3 DN downstream (from sensor)
- Fully filled sensor profile with liquid measured.
- High quality operational contact between the sensor and liquid measured.

*Measurement accuracy is interfered by:*

- Gassing of measured liquid and air bubbles
- Strong stray earth currents
- Liquid turbulence in the sensor
- Solids of magnetic metals in the medium measured

### Sensor option

- A measuring pipe is made of non-magnetic material with welded flanges and assembly clamps. An insulating liner with required properties is installed inside the pipe (according to the medium used). A system of driving coils generating the required magnetic field is directly fixed on the measuring pipe body.
- A pair of electrodes located opposite and passing through the measuring pipe with liner is made of high-grade steel and/or other material (according to the required chemical resistance against the medium being measured).
- The complete electrical section is assembled in steel housing (welded) with a neck for internal cabling.
- Remote version: A signal cable with the standard length of 8 m/ Cu type  $2 \times 2 \times 0.25 \text{ mm}^2$  is attached to the neck and the cable passes through a cable seal (also other lengths are available).
- Compact version: The instrument box body is attached to the neck.
- The housing welding makes it possible to achieve a high-grade protection and surface finish provides a steady climate resistance.

## Main unit option

- Control and evaluation electronics is assembled into robust aluminium housing with IP67 protection, or in case of remote version, protection of sensor is IP68.

### Additional option (customer request):

- Multi-point calibration of the measuring range. The flowmeters are usually calibrated in 3 points. On the customer's request, the number of calibration points can be increased.
- Higher sensor protection IP 68: the requirement must be precisely defined (i.e. immersion depth and time, and/or explosive zones).
- Higher PN, and/or different sensor built-in lengths, different flange options (DIN, ANSI, etc.), after consultation of your supply.

## Connection and assembly

Converter connection to power supply must be performed in compliance with the standards and rules:

- Connection of electrical instruments and appliances.
- Protection against electric shock.
- Heavy current distribution network in industrial plants.
- Safety operational rules for electrical installations operated by low-level experienced personnel.

If requested our Service Division will carry out commissioning. If work is done by any different organisation, the warranty can be cancelled in the case of such unauthorised work.

Electrical protection allows the use of the instrument in all kinds of active, passive and complex environments, and after an agreement with us, it is possible to carry out some additional modifications even for severe climatic conditions.

Signal and output cable routing should not be located near power output distribution network or in common ducts.

## Magnetic – induction sensors

Table for 1 m / s flowrates

DN	m <sup>3</sup> /h	l/min.	l/s
10	0,283	4,712	0,079
15	0,637	10,62	0,177
20	1,131	18,85	0,314
25	1,767	29,452	0,491
32	2,895	48,255	0,804
40	4,524	75,398	1,257
50	7,069	117,81	1,964
65	11,946	199,1	3,318
80	18,096	301,59	5,027
100	28,274	471,23	7,854
125	44,179	736,31	12,272

Constructional dimensions and weights of inductive sensors

DN	PN	Dimensions [mm]						Weight [kg]
		A	B	D1	D2	d	n	
10	16	150 or 200	266	90	60	14	4	2,5
15			268	95	65	14	4	2,5
20			273	105	75	14	4	3
25			280	115	85	14	4	3,5
32			293	140	100	18	4	5
40			298	150	110	18	4	6
50		200	304	165	125	18	4	7
65			322	185	145	18	4	8
80			337	200	160	18	8	9,5
100		250	358	220	180	18	8	12
125			389	250	210	18	8	15

150	63,617	1060,3	17,671
200	113,1	1885	31,42
250	176,71	2945,2	49,087
300	254,47	4241,2	70,686
350	346,36	5772,7	96,211
400	452,39	7539,8	125,66
450	572,26	9537,5	158,96
500	706,86	11781	196,35
600	1017,9	16965	282,74
700	1384,7	23079	384,65
800	1809,6	30159	502,65
900	2289,1	38151	635,85
1000	2827,4	47124	785,4

150	300	418	285	240	22	8	20
200	350	488	340	295	22	12	36
250	400	543	405	355	26	12	58
300	500	600	460	410	26	12	70
350		655	520	470	26	16	85
400	600	728	580	525	30	16	100
450		770	640	585	30	20	120
500		863	715	650	33	20	160
600		983	840	770	36	20	190
700	700	1040	910	840	36	24	260
800	800	1163	1025	950	39	24	350
900	900	1258	1125	1050	39	28	450
1000	1000	1398	1255	1170	42	28	550

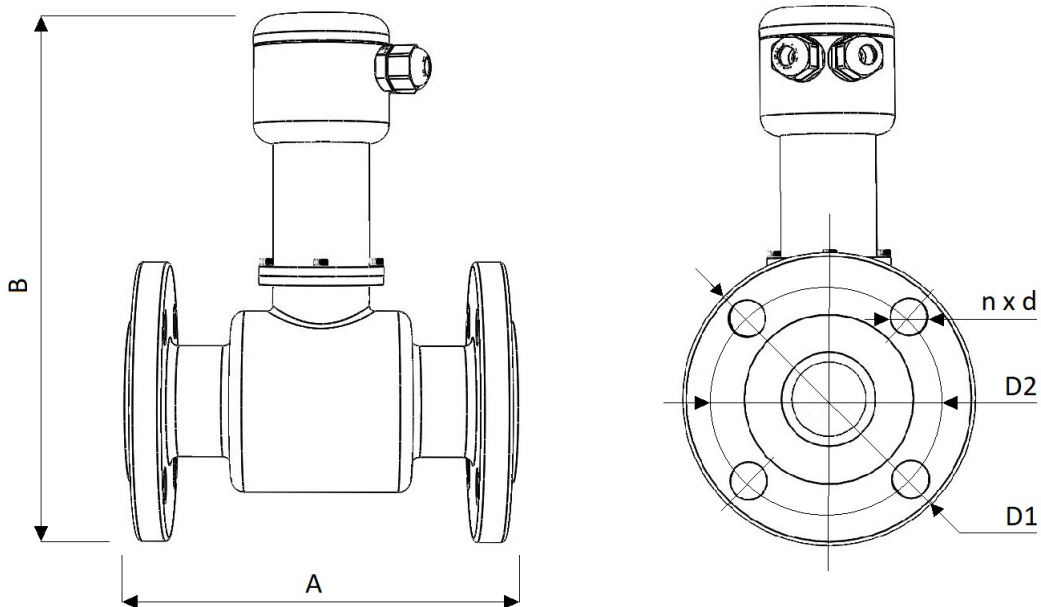

#### Tolerance of built-in lengths:

**DN 10 ÷ DN 150** →  $A \pm 5$  mm, **DN 200 ÷ DN 1000** →  $A \pm 10$  mm

#### Signal cable (connection between sensor and converter of the MIE-S):

- Signals which are transmitted from a sensor electrode circuit to the converter will be in a range of millivolts. They will be very sensitive to magnetic and electrostatic interference from neighboring high-voltage cables, power supply cables and high power output motors, etc. The interference is mainly compensated for by the converter connection, nevertheless if possible, it is necessary to prevent all spurious signals.
- The signal cable is of a special construction and length and is a part of the shipment, its length should not be changed (for certificated meter must not be changed). The proper cable connection to the converter is important; doing so may cause measurement failures. Special requirements are laid on shielding, and the measurement precision depends on its quality.

- The cable must not be extended.
- The shielding must be well insulated on the whole route from ground and the other metal subjects. It is recommended that the cable is located in a separate conduit or trays.

### Sensor location and its position in piping

- The inductive flowmeter sensor can be installed in any position according to requirements, however for horizontal assembly, the electrode axis must always be horizontal.
- Sensor must remain full of liquid.
- It is recommended that the flow direction should follow the arrow on the sensor cover; the converter is also preset for this direction. On the operating meter, it is possible to adjust the reverse flow direction by changing the MIE converter parameter.
- Bolts and nuts – verify if there is a sufficient space for their installation near flanges.
- Vibration and deflection of piping – fix the piping on both sides from the flowmeter to avoid any deflection and vibrations.
- If you install any pipes with higher internal diameters, install a reducer; this will provide an axial shift without increased mechanical stress of piping and sensor flanges.
- To improve flow, use only the recommended straight lengths upstream (5DN) and downstream (3DN) of the sensor. Any change of a diameter with an angle up to 8° is excluded from the above-mentioned straight lengths. Suitably assembled flow deflectors and a combination of diffusers are used in more sophisticated installations.
- When you install the sensor in insulated piping (e.g. glass, artificial mass, etc.), use proper sealing ground rings. A conductive connection between a sensor ground point and the liquid to be measured is needed for a proper measurement.

### Recommended positions for sensor installation

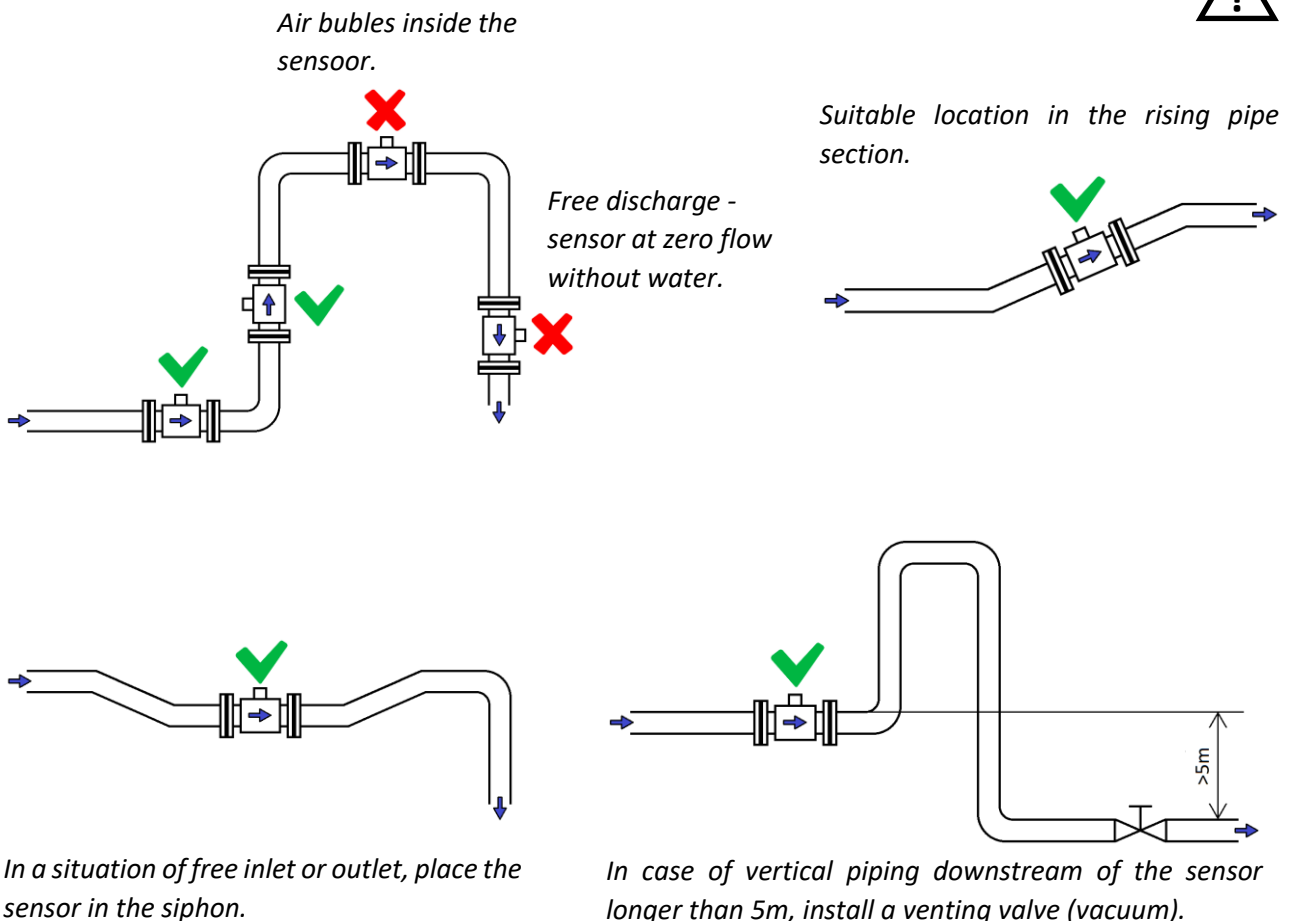



## Recommendations for installation

To avoid any measurement errors which are caused by air bubbles or failures on the lining, pay attention to the following recommendations:

- During assembling correctly seat the sensor, tighten screws uniformly and move on a diagonal one after another.
- It should be noted that the parallelism of flanges has a greater effect on packing than excessive tightening forces on curved and seated flanges.
- The sensor must be installed inside piping so that the axis of sensor electrode is always horizontal.
- A PTFE (teflon) lining calls for extra care during handling and assembly. During installation/operation avoid excessive under pressure in pipes. Please do not change and damage the outlet extension on both ends of the sensor. The sensors are shipped from the factory with special covers to avoid any shape deformations. (PTFE elastic memory should cause a partial compensation in future). Please remove the covers just before installation, and when you insert it between counter flanges, replace by a number of smooth metal sheet pieces which are removed just before tightening the bolts.
- Packing – The extended part of lining does not operate properly as a seal, hence appropriate packing must be inserted between sensor and pipeline. If the packing protrudes into a flow profile at any point, this will cause turbulence and reduce the measurement quality.
- During installation, make sure the sensor slides into piping if the pipeline is not flexible enough. It is recommended that installation inserts (especially for greater internal diameters) should be used. During installation of the sensor, counter flanges must not be welded (danger of the sensor lining failure).

## Sensor grounding

- For reliable and proper operation of the inductive meter, it is necessary to use high-quality protective grounding. Internal flowmeter cables and power supply PE (PEN) conductors provide protective grounding. Working grounding is also provided via internal cables and a high-quality connection of the sensor body with two metal pipe counter flanges. It is recommended that a connection made with M6 welded screws or bored threaded holes is used. The connection under flange fixing screws is not recommended because of possible corrosion resulting in measurement failures.
- When assembled into piping made from non-conductive material (or with non-conductive lining), it is necessary to provide working grounding with liquid by a different method, e.g. by grounding rings – valid for DN 10 ÷ DN 40. The rings can be ordered from factory, their material and chemical resistance must comply with the liquid to be measured – usually produced from the same material as sensor electrodes. The flowmeters from DN 50 ÷ DN 1000 are equipped of grounding electrode. Function of grounding electrode is same as grounding ring.
- When assembled, it is necessary to insert the packing on both sides of the grounding ring. Make sure that no parts will protrude into an internal sensor profile (turbulence).

Drawing of sensor working grounding inside pipeline

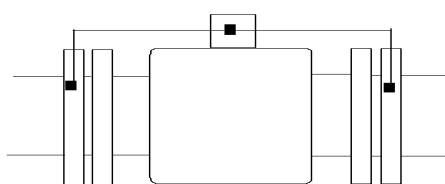

Use of grounding rings – valid for DN 10 ÷ DN 40

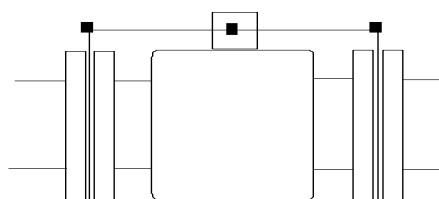

## Electrodes

- The electrode material must be selected according to its chemical resistance of the liquid to be measured.
- The electrode purity can affect the measurement precision, and high impurity concentration can affect the measurement process (liquid insulation).
- Immediately after shipping, it is not necessary to clean the electrodes before installing the sensor inside piping. Clean with a fine cloth, or use a chemical detergent. Avoid any damage of the lining! If the electrodes must be cleaned during operation, either mechanical or electrolytic methods may be used. Mechanical cleaning can only be used for a suitable sensor assembly, otherwise dismantle the sensor from the pipeline. After cleaning reinstall the sensor.
- Any electrolytic method is advantageous for its simplicity, however it can only be applied for the contamination that can be removed by electrolysis (low contamination and deposit).
- All detailed instructions are available from the flowmeter manufacturer on request.
- If a flowmeter operates under normal conditions, for most liquids it is not necessary to clean flowmeters during their life, only self-cleaning by flowing liquid is satisfactory (a recommended velocity is over 3 m/s).

## MIE commissioning

### Checking installation and connections

- Proper sensor and grounding.
- Tightening all cable connection clamps and plug in all connectors.
- For MIE-S verify the completeness of the shipped set according to the serial numbers of sensor and converter.
- Verify proper supply voltage; see the label on the converter.
- Verify proper electrical protection.
- If the installation is fault-free, fill the pipeline with liquid and verify the sensor tightness inside the pipeline. After short washout, switch the system on-off-on.

### Service

- The commercial, service and technical assistance for MIE is provided by Ela Brno, Ltd.
- The Service Division secures all activities that are related to the commissioning and all parameter changes at site (with the exception of certificated meters).
- Ela Brno, Ltd can authorise another organisation to provide service. The organisation must be able to submit the appropriate approval/certificate on request. The producer carries out recalibration of all meters and their repairs.

### Additional devices

- The additional devices are intended for remote control of the converter output signals (displaying and processing).
- The additional devices are not usually included in MIE shipment, but their type should be approved by the manufacturer. In such a case, the manufacturer is only responsible for the suitability of input parameters, and all other parameters are set according to the manufacturer's specifications of the additional devices.
- If a set is ordered without installation, the sensor is packed in corrugated paper and the converter is enclosed in a cardboard box or wooden palette.

## Packing and transport

- If the kit is ordered without assembly, the sensor is packed in bubble wrap (per pallet) and the control unit is paper boxes.
- The delivery can be carried out by a public carrier, the transport of the customer or the import by the production organization. The costs are paid by the customer.

## Connection



### Sensor connection

(compact version MIE – C)

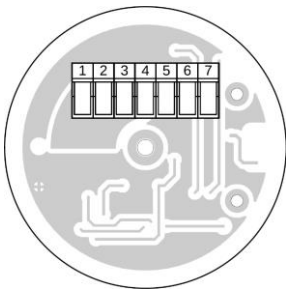

1	Electrodes	White	Red
2			Screen
3		Black	Red
4			Screen
5	Coils excitation	Green-yellow	
6		Yellow	
7		Blue	

### Sensor connection

(separated version MIE – S)

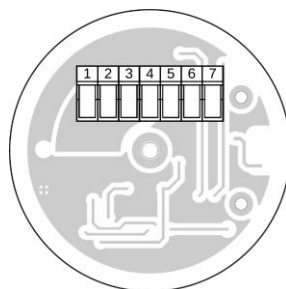

1	White
2	Screen
3	Brown
4	Green yellow - grounding
5	Screen
6	Yellow
7	Green

### Control unit communication connection

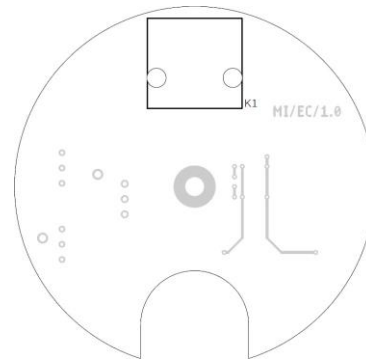

Connect the main unit to the Ethernet network with an RJ45 connector. Power is via passive PoE. The meaning of the RJ45 connector pins corresponds to the table:

Pin RJ45	Description
1	TX+
2	TX-
3	RX+
4	+24V <sup>1)</sup>
5	+24V <sup>1)</sup>
6	RX-
7	0V <sup>1)</sup>
8	0V <sup>1)</sup>

<sup>1)</sup> The device is equipped with overvoltage protection and protection against polarity reversal.

# MODBUS protocol

MODBUS protocol implementation conforms MODBUS Application Protocol Specification, version 1.1, modbus.org 12/06/02.

Device comes with default settings that are:

- slave address set to 1,
- baud rate 9600 Bps,
- 8 data bits, even parity, one stop bit.

Each MIE register takes two MODBUS registers, i.e. each MIE register is 32 bits long. These 32 bits are interpreted as an integer with or without a sign or as a floating point number with single precision. Double precision floating point numbers are stored in eight bytes, so they are transmitted in four MODBUS registers.

The MODBUS register with lower address is transferred first.

Device implements MODBUS functions 0x03 and 0x10.

### Coding of integers:

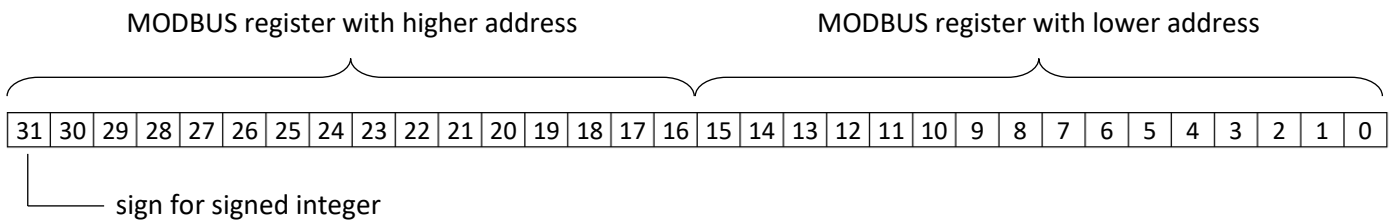

### Coding of floating point numbers:

#### Floating point numbers compatible with single type defined by IEEE 754.

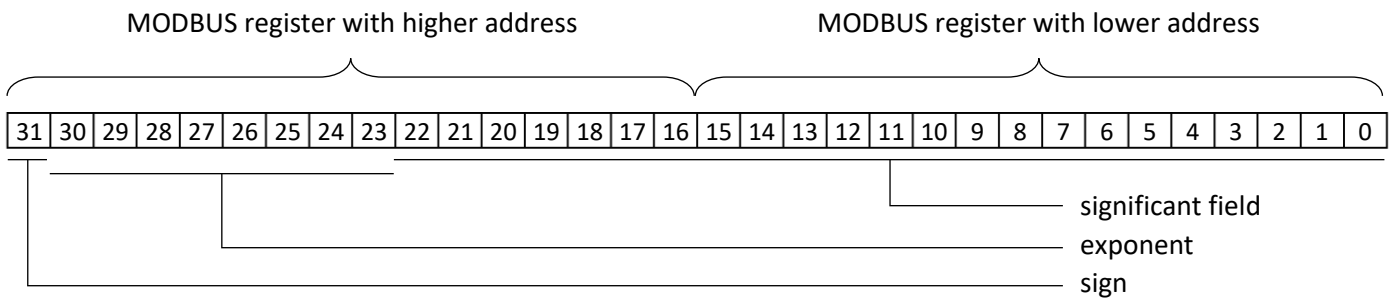

#### Floating point numbers compatible with Double type defined by IEEE 754.

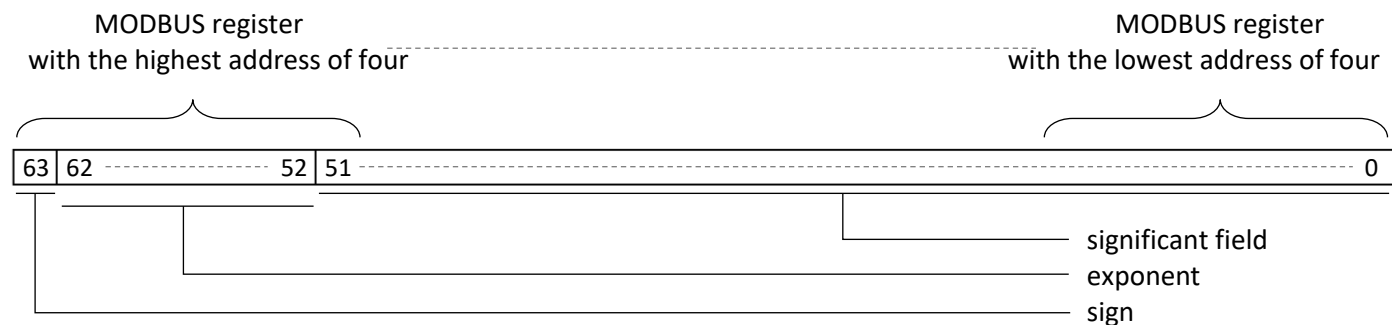

## Modbus registers

All registers are read only. For security reasons writing to registers is a bit more complex than reading, so the manufacturer provides configuration software which is free to charge.

Address		Type	Name	Unit	Description
[dec]	[hex]				
100	0064	unsigned int	Slave address		Slave device address in range from <u>1</u> to 247.
102	0066	unsigned int	Baud rate	Bps	Transmission rate, one value from 1200, 2400, 4800, <u>9600</u> , 14400, 19200, 28800, 38400, 57600.
104	0068	unsigned int	Parity		Transmission parity check, one value from 0 = no parity, <u>1</u> = even, 2 = odd, 3 = no parity, two stop bits.
106	006A	unsigned int	Pause	µs	Additional time in microseconds to extend silent interval between server request and slave response.
108	006C	unsigned int	Response time limit	µs	If slave device is not able to prepare response until this time expires, response isn't be send.
110	006E	unsigned int	Secondary flow unit		Unit of register 1024 <sub>(10)</sub> . Can be one from: 0 = l/s, <u>1</u> = m <sup>3</sup> /h, 2 = m <sup>3</sup> /s, 3 = l/min, 4 = UKgal/s, 5 = USgal/s.
1000	03E8	float	Q	l/s	Current flow, in litres per second.
1002	03EA	unsigned int	Main status		Bit 15: Parameter memory reading error. Neither measurement nor service function can be started. Bits <7, 0>: State of device: 0x00 ... idle time, 0x80 ... measurement is in progress, 0x80 to 0xFF ... service function is in progress.
1004	03EC	unsigned int	Alarms		Bit 31: excitation circuit failure, Bit 29: unfilled pipe error.
1008	03F0	float	CM		Main calibration constant (significant field)
1010	03F2	signed int	CE		Main calibration constant (exponent)
1020	03FC	float	Velocity	m/s	Flow velocity in meters per second.
1022	03FE	signed int	Temperature	°C	Converter temperature.
1024	0400	float	Q in secondary unit		Current flow in unit by register 110.
2000	07D0	double	S+	m <sup>3</sup>	Forward volume counter.
2004	07D4	double	S-	m <sup>3</sup>	Backward volume counter.
4002	0FA2	unsigned int	Back		Flow direction reversal. Q <sub>m</sub> is measured flow obtained by reading a register 1000 (or 1024) and Q is a real flow. If Back = 0 than Q = Q <sub>m</sub> otherwise Q = -Q <sub>m</sub> .
4004	0FA4	float	Cutoff low	%	Lower and upper limits for small flow suppression (hysteresis algorithm), in percentage of calibration range (register 8100 <sub>(10)</sub> ). Usual values are 0.4 and 0.6%.
4006	0FA6	float	Cutoff high	%	
8002	1F42	float	DN	mm	Nominal sensor size.
8100	1FA4	float	Calibrated range	l/s	
9002	232A	unsigned int	Device type		Device type:
9004	232C	unsigned int	Firmware version		for example 0x01090C00 = 1.9.12.0
9006	232E	unsigned int	Serial number		



## Declaration of conformity

**Product:** MQI 99 - C/S - SMART, MQU 99 - C/S - SMART, MHU 99 - C/S - SMART, MI, MIA, MIE, ESONIC, PU, CU

**Manufacturer:** ELA, spol. s r.o.  
Headquarter: Mikulovská 1, 628 00 Brno  
Office, workshop: Sokolova 32, 619 00 Brno

**Product description and designation:** flow and level measuring instruments

This Declaration of Conformity is issued under the sole responsibility of the manufacturer.

### The product above is in compliance with the following laws:

- Act No. 90/2016 Coll., On technical requirements for products
- Council Directive 2014/35 / EU (Government Regulation No. 118/2016 Coll. On conformity assessment of electrical equipment intended for use within certain voltage limits during their delivery to the market)
- Council Directive 2014/30 / EU (Government Regulation No. 117/2016 Coll., On Conformity Assessment of Products in terms of Electromagnetic Compatibility when Delivering to the Market)

### The following technical standards and specifications were used in the assessment:

- ČSN EN 61010-1 ed. 2
- ČSN EN 61326-1 ed. 2
- ČSN EN 61000-4-2 ed. 2
- ČSN EN 61000-4-3 ed. 3
- ČSN EN 61000-4-4 ed. 3
- ČSN EN 61000-4-5 ed. 3
- ČSN EN 61000-4-6 ed. 4
- ČSN EN 61000-4-8 ed. 2
- ČSN EN 61000-4-11 ed. 2

The device may only be installed, commissioned and repaired by a person instructed and authorized in accordance with applicable regulations.

Issued in Brno: 1.9.2020

Ing. Milan Vlček, Director of company



## Specifications

<b>Option</b>	compact version separated version (sensor installed under ground or under liquid level), fixed cable, cable length according to the order (max. 50 m)
<b>Nominal sizes</b>	flange DN 10 ÷ 1000 mm, without flanges DN 10 ÷ 100 mm
<b>Insulation class of excitation coils</b>	class E
<b>Connection</b>	flanged DIN (ANSI, BS, JIS) / hygienic - food DIN 11 851
<b>Maximum pressure</b>	standard 1,6 MPa (0,6 / 1,0 / 2,5 / 4,0 MPa)
<b>Liner material</b>	hard + soft rubber DN 10 ÷ DN 1000 / teflon PTFE DN 10 ÷ DN 500
<b>Electrodes</b>	stainless steel 316Ti (Hastelloy / Tantal / Titan / Platinum)
<b>Outer casing and flanges</b>	carbon steel standard (stainless steel 304, 321)
<b>Flow tube</b>	stainless steel 321
<b>External coating</b>	acrymetal multi component lacquer / polished stainless steel
<b>Protection</b>	IP67-NEMA5 (compact version) / IP68-NEMA6 (separated version)
<b>Media temperature</b>	compact version: 0 ÷ 90 °C separated version: hard rubber (0 ÷ 90 °C), PTFE (-20 ÷ 130 °C)
<b>Accessories options</b>	sensor grounding ring for plastic pipe for DN 10 ÷ DN 40 sensor grounding electrode for DN 50 ÷ DN 1000
<b>Special option</b>	food industry stainless steel version – teflon lining, fitting DIN 11 851 flange version with stainless steel cover – teflon / rubber lining flange all-stainless steel version – teflon / rubber lining without flange version – teflon / rubber lining
<b>Flow direction</b>	both direction
<b>Suppression of small flows</b>	yes
<b>Empty pipe detection</b>	yes
<b>Electrical conductivity of medium</b>	≥5 μS/cm, for demineralized water ≥20 μS/cm
<b>Accuracy of measurement</b>	0,5 % of measured value + 2 mm/s (reference conditions)
<b>Communication port</b>	ETHERNET, 10Base-T resp. 100Base-TX, protocol MODBUS TCP (instantaneous reading, parameters setting and calibration)
<b>Power supply</b>	9 ÷ 36 V DC / 10 W
<b>Main unit protection</b>	IP67 - NEMA5
<b>Ambient temperature</b>	-20 ÷ 60 °C

**Headquarters / Service**

ELA, spol. s r. o.  
Sokolova 32  
619 00 Brno  
Czech Republic

**Billing address**

ELA, spol. s r.o.  
Mikulovská 1  
628 00 Brno  
Czech Republic

IČO:46969063  
DIČ:CZ46969063

More on: [www.elabrno.cz/contacts](http://www.elabrno.cz/contacts)